



S4

STAMFORD®

DIMENSIONS

Drawings represent standard design
All dimensions in millimetres (mm)

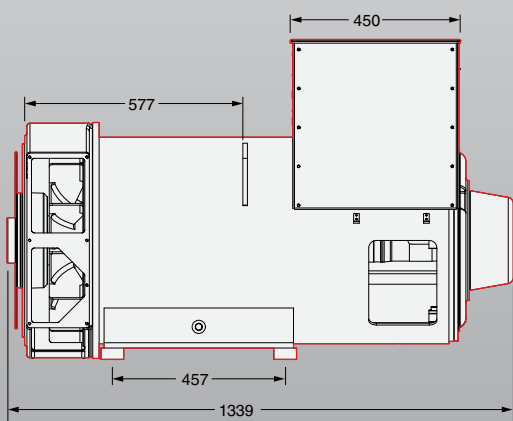
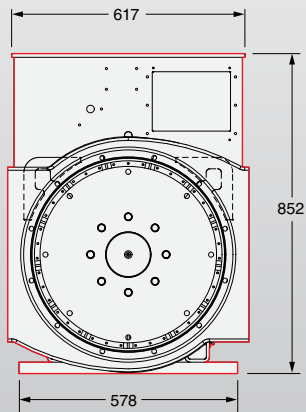

**3 YEAR
WARRANTY**

Model	S4
Maximum continuous rating at 50Hz (kVA)	450
Maximum continuous rating at 60Hz (kVA)	560

Specifications	
Voltage Range	380-690
Poles	4
Technology	Wire Wound
AVR	Analogue
Voltage sensing	2-Phase
Bearing Arrangement	Single
SAE Adaptors	0, 0.5, 1, 2, 3
Terminals	12
Material Insulation Class	H
Excitation System	Self exciting
Ingress Protection	IP23
Connection with other machines	Paralleling capability

Optional Features	
Excitation System	PMG
Bearing Arrangement	Double
Ingress Protection	IP23 Air Filters
Output configurations	1 phase re-connectable
Voltage sensing	3-Phase sensing
AVR	Digital
Temperature monitoring	Winding RTDs
Temperature monitoring	Thermistors
Environmental protection	Anti-condensation Heaters
Foot options	Adaptor Foot Flexible Foot

Designed For	
Grid Code Compatible	●
Marine Auxiliary	●
Oil & Gas Auxiliary	●
Combined Heat & Power	●
Critical Protection & UPS	●
Continuous Power & Standby	●

Prime Movers	
Diesel Engine	●
Gas Engine	●