

# STAMFORD® S5

Model	S5
Maximum continuous rating at 50Hz (kVA)	750
Maximum continuous rating at 60Hz (kVA)	937

Specifications	
Voltage Range	380-690
Poles	4
Technology	Wire Wound
AVR	Analogue
Voltage sensing	2-Phase
Bearing Arrangement	Single
SAE Adaptors	00, 0, 0.5, 1
Terminals	12
Material Insulation Class	H
Excitation System	Self exciting
Ingress Protection	IP23
Connection with other machines	Paralleling capability

Optional Features	
Excitation System	PMG
Bearing Arrangement	Double
Ingress Protection	IP23 Air Filters
Output configurations	3 phase re-connectable
Voltage sensing	3-Phase sensing
AVR	Digital
Temperature monitoring	Winding RTDs
Temperature monitoring	Thermistors
Environmental protection	Anti-condensation Heaters

Designed For	
Grid Code Compatible	●
Marine Auxiliary	●
Oil & Gas Auxiliary	●
Combined Heat & Power	●
Critical Protection & UPS	●
Continuous Power & Standby	●

Prime Movers	
Diesel Engine	●
Gas Engine	●

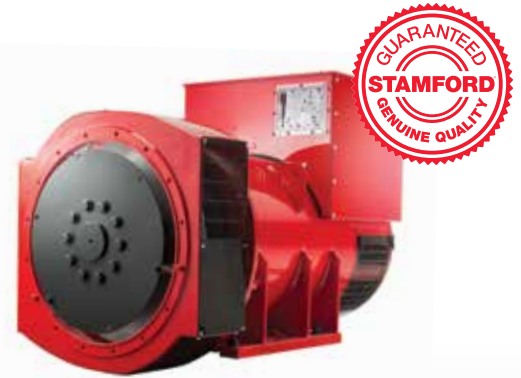

## DIMENSIONS

Drawings represent standard design  
All dimensions in millimetres (mm)

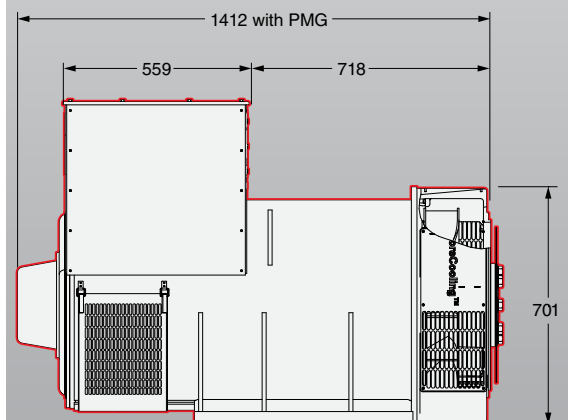
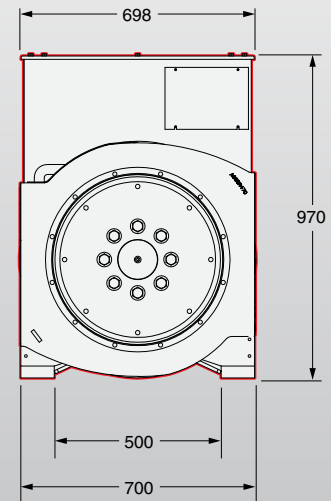

**3 YEAR WARRANTY**